

Reconstruction services

MARLEY® 

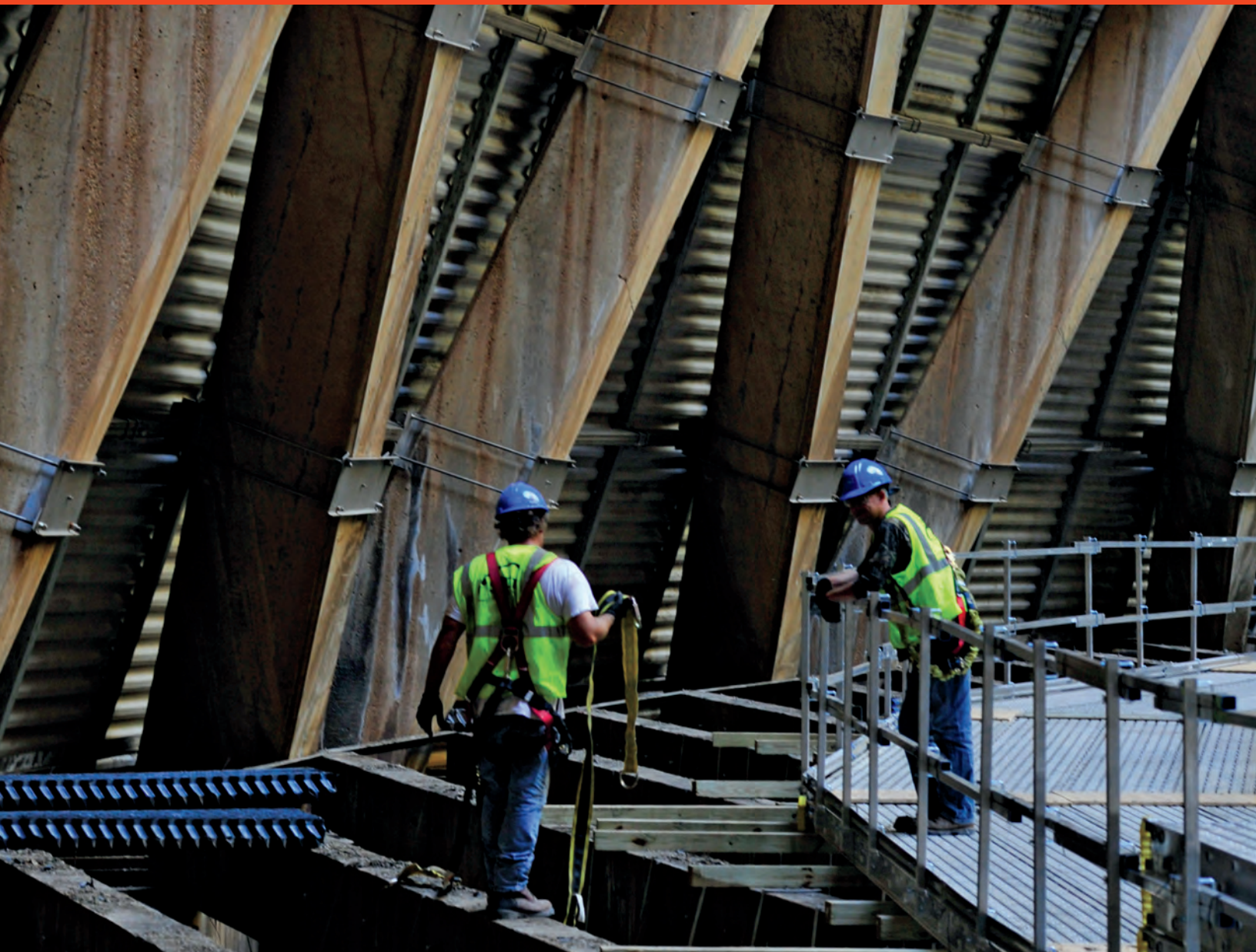



A s G o o d A s N e w , E v e n B e t t e r .

■ Our Philosophy.

SPX Cooling Technologies has designed, manufactured, and constructed more field-erected cooling towers than all other manufacturers combined. Key to our success has been our philosophy that all components be designed to work specifically in cooling tower environments as an integrated system. We apply that same fundamental principle to our integrated reconstruction process for older cooling towers to make them as good as new, or even better.

■ Reconstruction Sales and Service.

Services include all aspects of reconstruction, repair and parts with the goal of restoring your cooling tower system to its optimum thermal performance and structural integrity.



■ Marley Temporary Cooling Solutions.

Bundle your next reconstruction project with Marley Rental cooling towers. Marley Temporary Cooling Solutions is geared entirely toward making your performance our priority – including a fleet of ultra-efficient induced-draft rental towers, and regional support teams who are on the ground and ready to move.

■ Upgrade Performance.

By utilizing cooling tower technology that may not have existed when your cooling tower was built, our engineers can upgrade the thermal performance of your cooling tower. This can even be accomplished on-line, providing you with the option of not having to interrupt your process operation or revenue stream.

As the world's most respected name in cooling towers, we're experts when it comes to prolonging the life of your cooling tower with preventive maintenance, diagnostic services, restoration, reconstruction and upgrading programs.

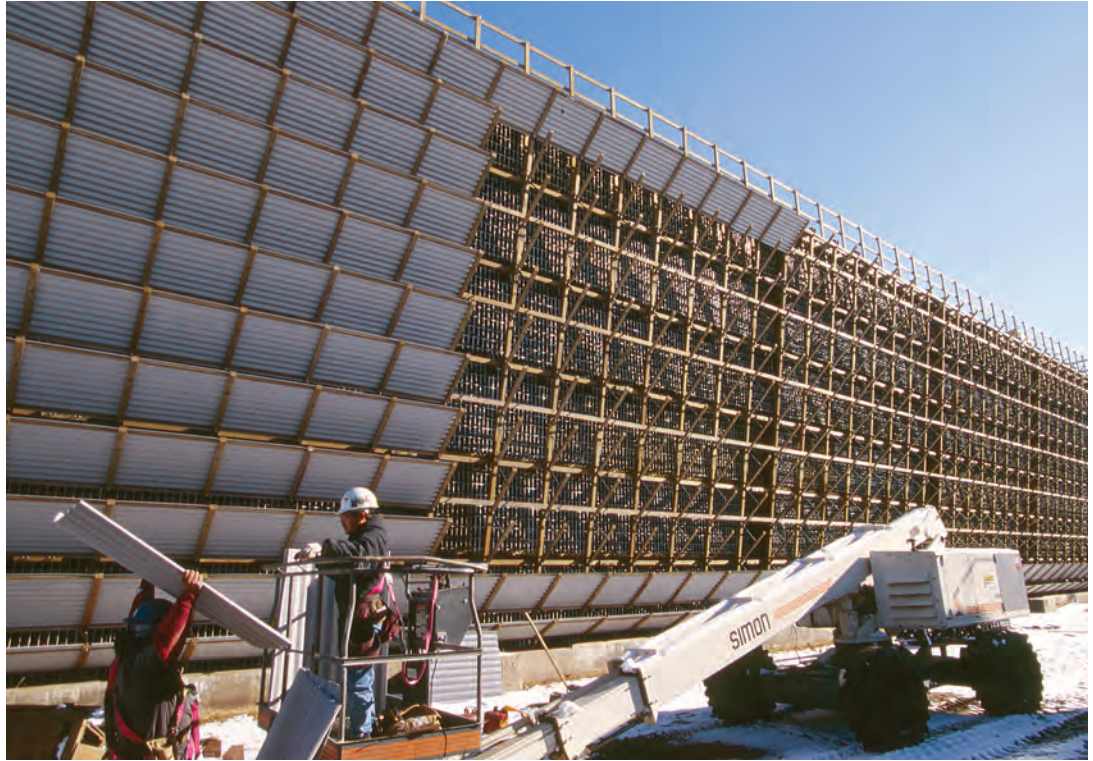

We know your cooling tower inside and out.

■ **Cooling Tower Specialists.**

SPX Cooling Technologies employs more full-time engineers specializing in cooling tower construction and operation than any other company in the industry. Since 1883, our engineers have designed and manufactured virtually every type of cooling tower. We are familiar with all manufacturers' cooling tower designs, parts and components.

■ **Valuable Experience.**

Our engineers, with years of first-hand experience backed by the industry's finest research and development information, know the adverse effects environmental conditions can have on structural integrity, parts operation and thermal performance. We know what works, what doesn't work, and, more importantly, we know why.

Unique on-line construction techniques offers an outstanding way to affect a repair or reconstruction project without shutting down the cooling tower.



■ Construction Expertise.

SPX Cooling Technologies provides single-source construction services capable of conducting off or on-line reconstruction services without shutting down your cooling tower. We only use authorized subcontractors who are supervised on-site by fully trained full-time SPX superintendents .

Your cooling tower work is entrusted only to experienced crews who are completely familiar with cooling tower construction and know how to manage the job site to reduce potential hazards.

■ Reconstruction Experts.

Experience definitely gives SPX an edge when it comes to determining your cooling tower reconstruction needs. Considering the great majority of cooling tower parts or components were either manufactured by Marley, or based upon one of our original designs, we have an acute understanding of how they work together, what needs to be changed, what needs to be left alone, and what can be done to upgrade your system's thermal performance.

System integration

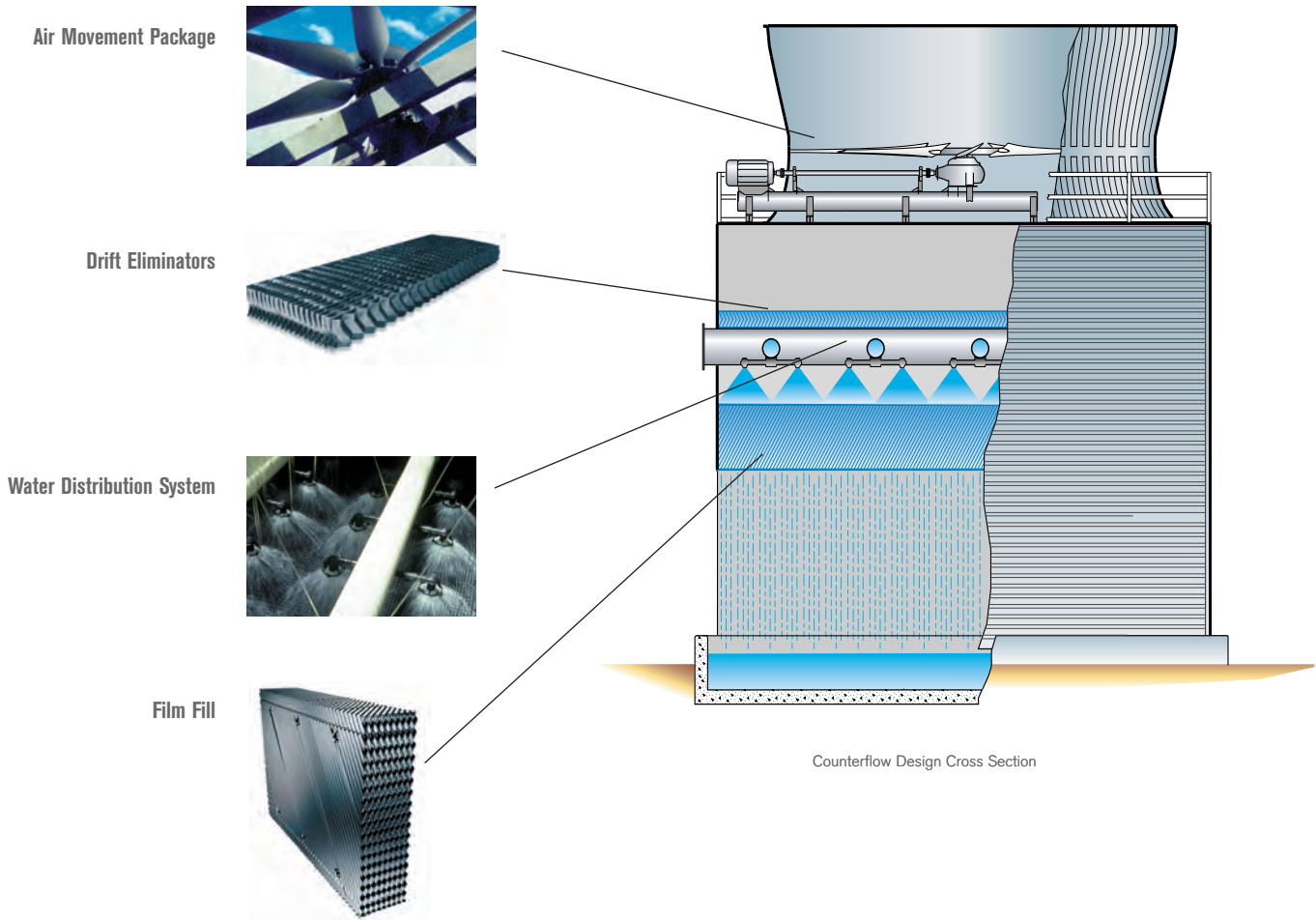

Counterflow

Basic Method of Operation – The fan draws air vertically through the tower counter to the water descending through the fill and into the basin.

Crossflow

The vertical discharge doubleflow design was developed and patented by Marley in 1938.

Basic Method of Operation – The fan draws air horizontally across the fill as water descends through the fill and into the basin.

gives you the edge.

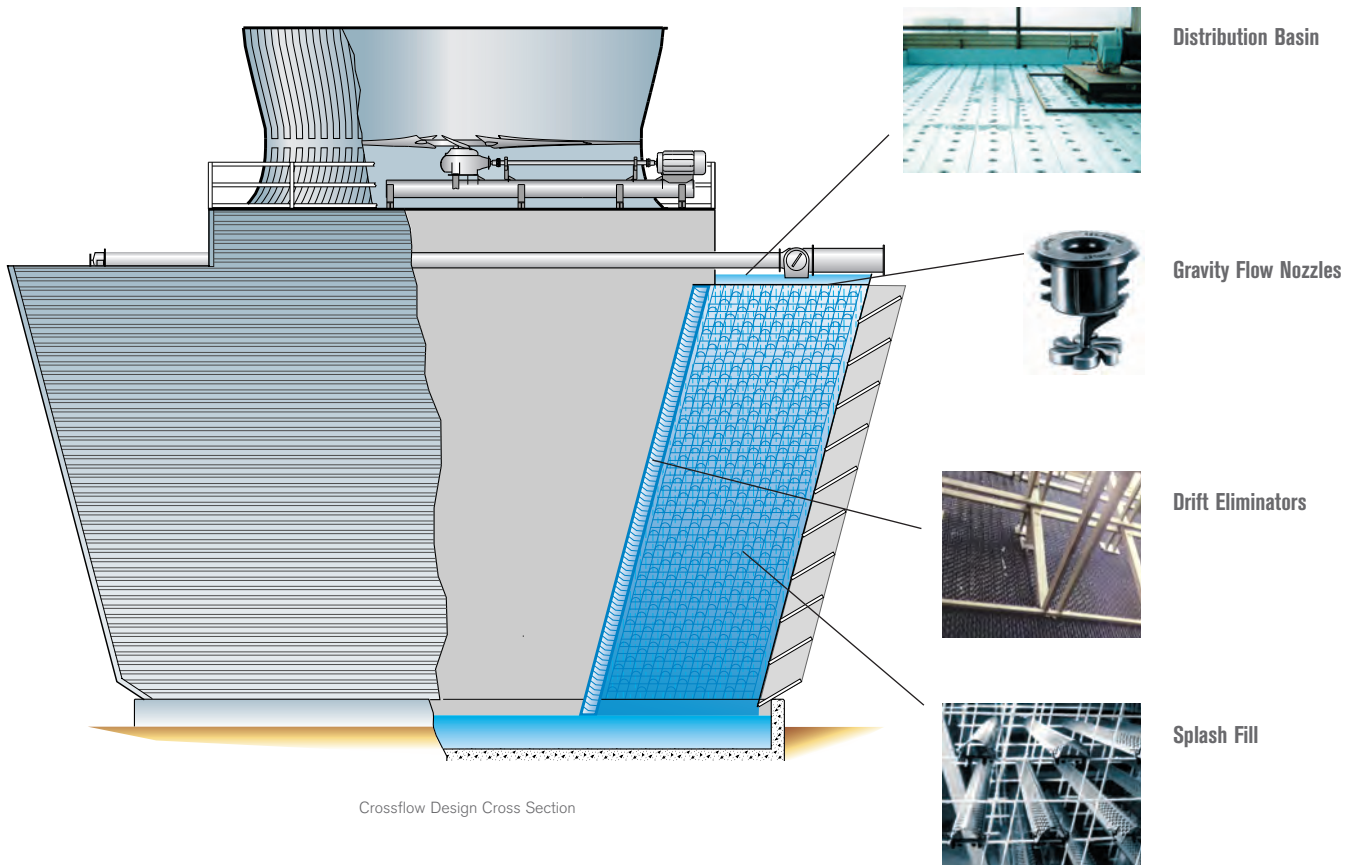

Unique single-source manufacturing philosophy offers your tower the opportunity for the most efficient performance.

System-enhancing components for both counterflow and crossflow designs, Marley towers or others.

- Fans
- Fan cylinders
- Driveshafts
- Geareducers
- Mechanical equipment supports
- Belt drive components
- Fill
- Nozzles
- Drift eliminators
- Valves
- Structural components
- Casing
- Louvers
- Distribution systems

Designed, tested, manufactured, installed, proven.

Steps involved in the SPX Integrated Reconstruction Process:



■ Inspection

The reconstruction process begins with a thorough inspection of your tower. These inspections ascertain the current condition of your cooling tower and identify operational and structural problems. Recommendations are made in regard to the scope of work, including re-use or replacement of primary components.

■ Analysis

To determine the structural integrity and actual thermal performance capability of your cooling tower, SPX Cooling Technologies encourages CTI performance status testing. Analysis of your tower is supported by the research and development laboratory and testing facilities of SPX Cooling Technologies' industry leading R&D center. Resulting recommendations reflect either the minimum work necessary to satisfy your thermal performance requirements or indicate the maximum effort needed to bring your cooling tower to achieving your requirements.

■ Engineering

Once the necessary work has been determined and your thermal performance objectives established, our engineers apply the same design standards to reconstruction as we do to new tower construction. This ensures that all changes made to the cooling tower are designed to work together to achieve the thermal performance objectives.

The predictable performance of a cooling tower depends on the interdependence of various components working together as a system. Because alteration of any one component can alter the entire system, it may be necessary to modify one or more of the remaining components in the system to restore balance. No mix and match combinations of components are used which have not been previously tested as a system.



■ Fabrication

Components are manufactured by Marley in accordance with strict cooling tower specifications. Every component is tested for performance and reliability as a system to ensure quality and compatibility. All structural components meet or exceed standards set by the Cooling Technology Institute. Parts and components are available for quick shipment.

■ Construction

Dedicated SPX construction crews perform all work paying attention to the details. Fully understanding the potential hazards associated with cooling tower construction, they adhere to strict safety standards and practices. But what sets them apart from all other construction crews is their superior knowledge and experience with not only Marley parts, components, construction and standards, but those of many different manufacturers. All of which ensures specified thermal performance and structural integrity for years to come.

■ Post Analysis

Upon completion of your cooling tower renewal, our engineers perform post construction inspections, and as necessary conduct thermal testing, and performance evaluations to ensure that specified objectives and upgrades have been fulfilled and all performance guarantees are satisfied.

SPX Cooling Technologies works for you.



Customer Service

We're committed to providing the most responsive customer service in the industry. As part of this commitment, we offer these additional services:

- Immediate and effective support and guidance for maintenance departments.
- Inspections and condition reports
- Computerized order entry and scheduling of parts shipments
- Performance testing to determine your cooling tower's actual thermal performance capability
- Backfit of current components to existing towers
- Custom-designed replacement cooling towers over existing cold water basins or supports
- A complete and readily accessible replacement parts inventory covering all primary cooling tower components



- Marley Geareducer[®] rebuilding service
- Regional reconstruction teams to provide the fastest response
- Emergency Service Team[™] – one call to your rep gets you an immediate response 24 hours a day, 365 days a year
- SPX Cooling Technologies manufactures, installs and warrants all cooling tower components and associated performance
- Extend [™] maintenance agreements tailored to individual customers
- The highest industry standards for safety practices

The Safe Choice Is Always SPX.



- “Zero Falls Policy” protection program
- Cooling tower specific safety orientation and training
- Professional safety management program
- Alcohol and drug abuse policy
- Safety training program
- Job site safety audits

SPX COOLING TECHNOLOGIES, INC.

7401 WEST 129 STREET
OVERLAND PARK, KS 66213 USA
913 664 7400 | spxcooling@spx.com
spxcooling.com

RECON-11 | ISSUED 08/2016
COPYRIGHT © 2016 SPX CORPORATION

In the interest of technological progress, all products are subject to design and/or material change without notice.

